

Remote I/O Boxes



ADIO-EC PRODUCT MANUAL

For your safety, read and follow the considerations written in the instruction manual, other manuals and Autonics website.

The specifications, dimensions, etc. are subject to change without notice for product improvement. Some models may be discontinued without notice.

Features

- The upper level communication protocol: EtherCAT
- The lower level communication protocol: IO-Link ver. 1.1 (port class: Class A)
- Housing material: Zinc Die casting
- Protection rating: IP67, IP69K
- The daisy chain allows the power supply using the connection technology in a standardized 7/8" connector
- The maximum output current of power supply: 2 A per port
- I/O port settings and status monitoring (cable short / disconnection, connection status, etc.)
- Supports digital input filter

Safety Considerations

- Observe all 'Safety Considerations' for safe and proper operation to avoid hazards.
- ⚠ symbol indicates caution due to special circumstances in which hazards may occur.

⚠ Warning Failure to follow instructions may result in serious injury or death.

- 01. Fail-safe device must be installed when using the unit with machinery that may cause serious injury or substantial economic loss. (e.g. nuclear power control, medical equipment, ships, vehicles, railways, aircraft, combustion apparatus, safety equipment, crime/disaster prevention devices, etc.)**
Failure to follow this instruction may result in personal injury, economic loss or fire.
- 02. Do not use the unit in the place where flammable/explosive/corrosive gas, high humidity, direct sunlight, radiant heat, vibration, impact or salinity may be present.**
Failure to follow this instruction may result in explosion or fire.
- 03. Do not connect, repair, or inspect the unit while connected to a power source.**
Failure to follow this instruction may result in fire.
- 04. Check 'Connections' before wiring.**
Failure to follow this instruction may result in fire.
- 05. Do not disassemble or modify the unit.**
Failure to follow this instruction may result in fire.
- 06. Do not touch the product during operation or for a certain period of time after stopping.**
Failure to follow this instruction may result in burn.

⚠ Caution Failure to follow instructions may result in injury or product damage.

- 01. Use the unit within the rated specifications.**
Failure to follow this instruction may result in fire or shortening the life cycle of the product.
- 02. Use a dry cloth to clean the unit, and do not use water or organic solvent.**
Failure to follow this instruction may result in fire.
- 03. Keep the product away from metal chip, dust, and wire residue which flow into the unit.**
Failure to follow this instruction may result in fire or product damage.
- 04. Connect the cable correctly and prevent poor contact.**
Failure to follow this instruction may result in fire or product damage.
- 05. Do not connect or cut off the wire of the cable while operating the unit.**
Failure to follow this instruction may result in fire or product damage.

Cautions during Use

- Follow instructions in 'Cautions during Use'. Otherwise, it may cause unexpected accidents.
- The UA power (actuator power) and US power (sensor power) should be insulated by the individually isolated power device.
- Power supply should be insulated and limited voltage/current or Class 2, SELV power supply device.
- Use the rated standard cables and connectors. Do not apply excessive power when connecting or disconnecting the connectors of the product.
- Keep away from high voltage lines or power lines to prevent inductive noise. In case installing power line and input signal line closely, use line filter or varistor at power line and shielded wire at input signal line. For stable operation, use shield wire and ferrite core, when wiring communication wire, power wire, or signal wire.
- Do not use near the equipment which generates strong magnetic force or high frequency noise.
- Do not connect, or remove this unit while connected to a power source.
- This unit may be used in the following environments.
 - Indoors (in the environment condition rated in 'Specifications')
 - Altitude max. 2,000 m
 - Pollution degree 2
 - Installation category II

Configuration of ADIO-EC

The figure below shows the EtherCAT network and the devices that compose it. For proper use of the product, refer to the manuals and be sure to follow the safety considerations in the manuals. Download the manuals from the Autonics website.

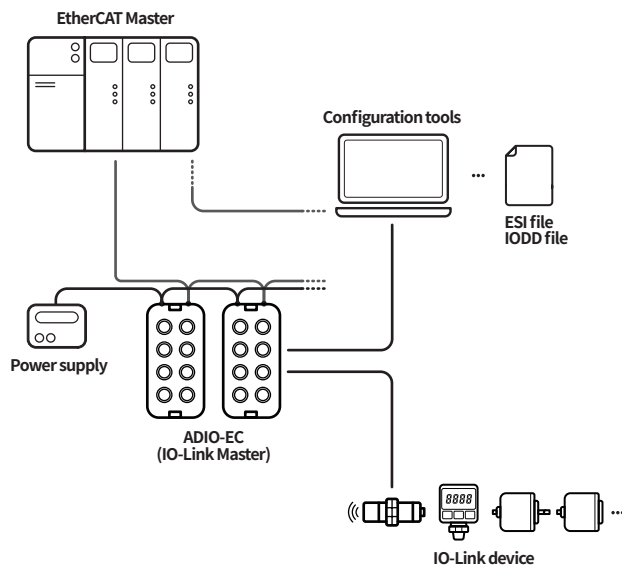

STEP		Reference manual
Hardware installation	Install and ground the ADIO	ADIO-EC Product Manual
	Connect the ports of ADIO	
	Supply power to the ADIO	
IO-Link device settings	Set parameters and functions of IO-Link device	atIOLink User Manual
EtherCAT Master ↔ ADIO-EC	Integrate the ADIO-EC to the TwinCAT 3	TwinCAT 3 Guide ⁰¹⁾
	Set the ports of ADIO-EC	
Checking the operation	Check the indicators	ADIO-EC Product Manual

⁰¹⁾ The purpose of this document is to provide supplementary information for users' convenience. The project planning software of the upper level communication system may be different depending on the user's environment. For more information, refer to the manufacturer's manual.

■ The supported objects

Operation mode	Safe State ⁰¹⁾	Validation	Data Storage	Input Filter ⁰¹⁾	Vendor ID	Device ID	Cycle Time
Digital Input	-	-	-	○	-	-	-
Digital Output	○	-	-	-	-	-	-
IO-Link Input	-	○	○	-	○	○	○
IO-Link Output	-	○	○	-	○	○	○
IO-Link Input/Output	-	○	○	-	○	○	○

⁰¹⁾ Unsupported on the atIOLink

Software

Download the installation file and the manuals from the Autonics website.

■ atIOLink

"atIOLink" is the Port and Device Configuration Tool (PDCT).

It supports the settings for ports and devices in the Field Network.

Ordering Information

This is only for reference, the actual product does not support all combinations. For selecting the specified model, follow the Autonics website.

ADIO - EC - MA 08 A ① - ILM

① I/O specification

N: NPN

P: PNP

Product Components

- Product × 1
- Name plates × 20
- M4 × 10 screw with washer × 1
- Instruction manual × 1
- Waterproof cover × 4

Sold Separately

- Name plates
- Waterproof cover

Connections

■ Ethernet port

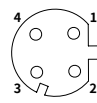
M12 (Socket-Female), D-coded	Pin	Function	Description
	1	TX +	Transmit Data +
	2	RX +	Receive Data +
	3	TX -	Transmit Data -
	4	RX -	Receive Data -

■ Power supply port

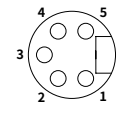
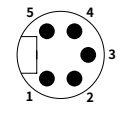
OUT (7/8", Socket-Female)	IN (7/8", Plug-Male)	Pin	Function	Description
		1, 2	0V	Sensor and actuator supply
		3	F.G.	Frame ground
		4	+24 VDC≡	Sensor supply
		5	+24 VDC≡	Actuator supply

■ PDCT port

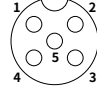
M12 (Socket-Female), A-coded	Pin	Function
	1	Not Connected (N.C.)
	2	Data -
	3	0V
	4	Not Connected (N.C.)
	5	Data +

■ I/O port

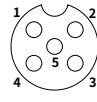
M12 (Socket-Female), A-coded	Pin	Function
	1	+24 VDC≡
	2	I/Q: Digital Input
	3	0V
	4	C/Q: IO-Link, Digital Input/Output
	5	Not Connected (N.C.)

Dimensions

• Unit: mm, For the detailed dimensions of the product, follow the Autonics website.

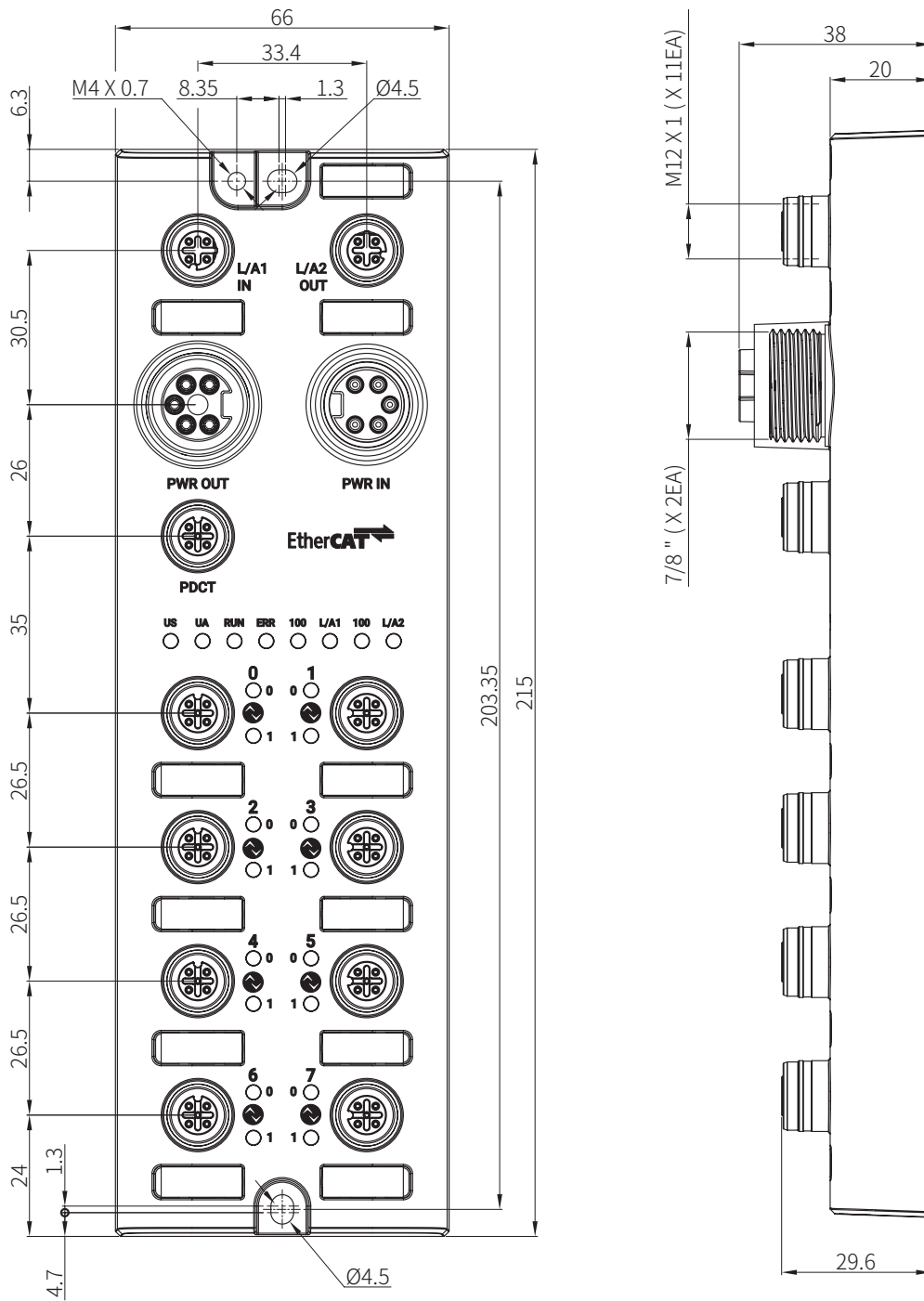

Unit Descriptions

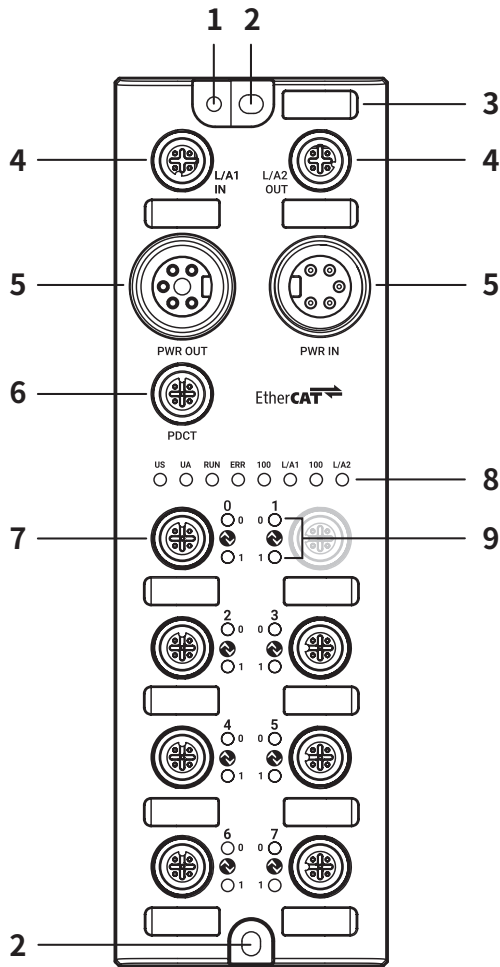

- | | |
|---------------------------------------|------------------------|
| 01. Grounding hole | 04. Ethernet port |
| 02. Mounting hole | 05. Power supply port |
| 03. Insertion part for the name plate | 06. PDCT port |
| | 07. I/O port |
| | 08. Status indicator |
| | 09. I/O port indicator |

Installation

■ Mounting

01. Prepare a flat or metal panel in the enclosure.
02. Drill a hole to mount and ground the product on the surface.
03. Turn off all power.
04. Fix the product using M4 screws in the mounting holes.
Tightening torque: 1.5 N m

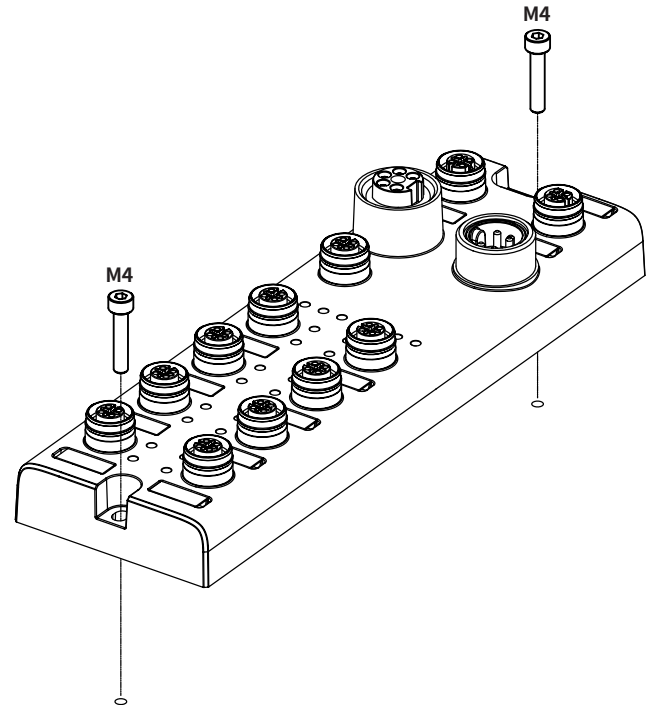

■ Grounding

⚠ Be sure to use a cable with low impedance and as short as possible for connecting the housing to the product.

01. Connect the grounding strap and M4 × 10 screw with washer.
02. Fix the screw in the grounding hole.
Tightening torque: 1.2 N m

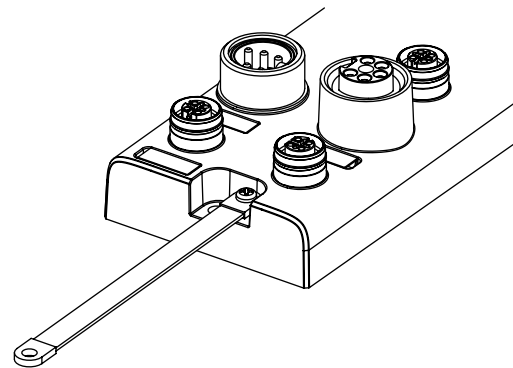



Port Connections

■ Port specifications

- Be sure to check the port specifications below before connecting the device. Prepare a cable that complies with the protection rating IP67/IP69K.

	Ethernet port	I/O port	PDCT port	Power supply port
Type	M12 (Socket-Female), 4-pin, D-coded	M12 (Socket-Female), 5-pin, A-coded	M12 (Socket-Female), 5-pin, A-coded	Input: 7/8" (Plug-Male), 5-pin Output: 7/8" (Socket-Female), 5-pin
Push-Pull	YES	YES	YES	N.A
Number of ports	2	8	1	2
Tightening torque	0.6 N m	0.6 N m	0.6 N m	1.5 N m
Supported function	Daisy chain	-	USB serial communication	Daisy chain

- The example of communication cable for the PDCT port

Connector 1	Connector 2	Wiring			
		Connector 1 Pin no.	Connector 1 Function	Connector 2 Pin no.	Connector 2 Function
M12 (Plug-Male), 5-pin	USB Type A (Plug-Male)	1	N.C.	-	-
		2	Data -	→ 3	Data -
		3	0 V	→ 1	0 V
		4	N.C.	4	+ 5 VDC≡
		5	Data +	→ 2	Data +

01. Connect to the EtherCAT

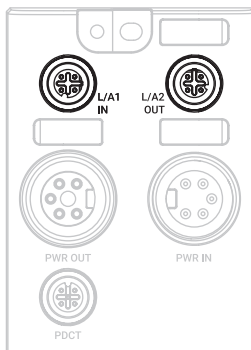

01. Connect the M12 connector to the EtherCAT port. See the connections below.

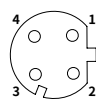

1	TX +	Transmit Data +
2	RX +	Receive Data +
3	TX -	Transmit Data -
4	RX -	Receive Data -

02. Connect the connector to the EtherCAT network.
 - Network device: PLC or EtherCAT device supporting EtherCAT protocol
03. Put the waterproof cover on the unused port.

02. Connect the IO-Link devices

- ⚠ The maximum output current is 2 A at each I/O port. Configure the device so that the total current of the I/O ports does not exceed 9 A.
- ⚠ Check the wiring information in the manual of the IO-Link device to be connected.

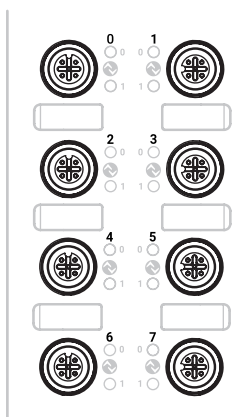

01. Connect the M12 connector to the I/O port. See the connections below.



1	+24 VDC≡
2	I/Q: Digital Input
3	0 V
4	C/Q: IO-Link, Digital Input/Output
5	Not Connected (N.C.)

02. Put the waterproof cover on the unused port.

03. Connect with the atIOLink

⚠ Do not use the PDCT port and the Ethernet port at the same time.

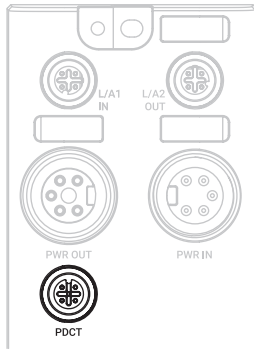

01. Connect the M12 connector to the PDCT port. See the connections below.



1	Not Connected (N.C.)
2	Data -
3	0 V
4	Not Connected (N.C.)
5	Data +

02. Connect the connector to the network device.

- Network device: PC/laptop that atIOLink software is installed

03. Put the waterproof cover on the unused port.

04. Connect the power supply to ADIO

⚠ Be sure not to exceed 9 A of the maximum supplying current to the sensor (US).

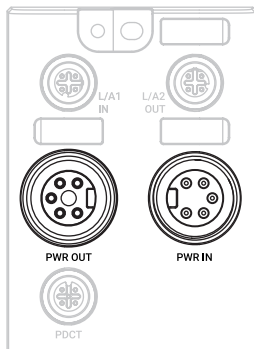

01. Turn off all power.

02. Connect the 7/8" connector to the power supply port. See the connections below.

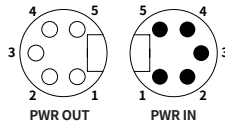

1, 2	0 V	Sensor and actuator supply
3	F.G.	Frame ground
4	+24 VDC	Sensor supply
5	+24 VDC	Actuator supply

Indicators

■ Status indicator



01. The power supply of sensor

Indicator	LED Color	Status	Description
US	Green	ON	Applied voltage: normal
	Red	Flashing (1 Hz)	Applied voltage: low (< 18 VDC=)

02. The power supply of actuator

Indicator	LED Color	Status	Description
UA	Green	ON	Applied voltage: normal
	Red	Flashing (1 Hz)	Applied voltage: low (< 18 VDC=)
		ON	Applied voltage: none (< 10 VDC=)

03. Product initialization

Indicator	LED Color	Status	Description
US, UA	Red	ON	ADIO initialization failure

04. EtherCAT State Machine

Indicator	LED Color	Status	Description
RUN	Green	OFF	EtherCAT state: INIT
		Flashing	EtherCAT state: PRE-OPERATIONAL
		Flashing (once)	EtherCAT state: SAFE-OPERATIONAL
		ON	EtherCAT state: OPERATIONAL

05. Error alert

Indicator	LED Color	Status	Description
ERR	Red	OFF	No error
		Flashing	Invalid configuration
		Flashing (once)	Local error
		ON	Error in application

06. Ethernet connection

Indicator	LED Color	Status	Description
L/A1 L/A2	Green	OFF	No Ethernet connection.
		ON	The Ethernet connection is established.

07. Transmission rate of the Ethernet

Indicator	LED Color	Status	Description
100	Green	ON	Transmission rate: 100 Mbps

■ I/O port indicator

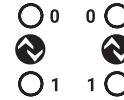

01. Pin 4 (C/Q)

Indicator	LED Color	Status	Description
0	Yellow	OFF	DI/DO: pin 4 OFF
		ON	DI/DO: pin 4 ON
	Green	ON	Port configuration: IO-Link
		Flashing (1 Hz)	Port configuration: IO-Link, No IO-Link device found
	Red	Flashing (2 Hz)	IO-Link configuration error
		ON	Short circuit occurred on pin 4

02. Pin 2 (I/Q)

Indicator	LED Color	Status	Description
1	Yellow	OFF	DI: pin 2 OFF
		ON	DI: pin 2 ON

03. The power supply of the I/O port

Indicator	LED Color	Status	Description
0,1	Red	Flashing (1 Hz)	Short circuit occurred in the I/O supply power (pin 1, 3)

Specifications

Electrical/Mechanical specifications

Supply voltage	18 - 30 VDC≐
Rated voltage	24 VDC≐
Current consumption	2.4 W (≤ 216 W)
Supplying current per port	≤ 2 A/Port
Sensor current (US)	≤ 9 A
Dimensions	W 66 × H 215 × D 38 mm
Material	Zinc Die casting
Ethernet port	M12 (Socket-Female), 4-pin, D-coded, Push-Pull Number of ports: 2 (IN/OUT) Supported function: daisy chain
Power supply port	Input: 7/8" (Plug-Male), 5-pin Output: 7/8" (Socket-Female), 5-pin Number of ports: 2 (IN/OUT) Supported function: daisy chain
PDCT port	M12 (Socket-Female), 5-pin, A-coded, Push-Pull Number of ports: 1 Connection method: USB serial communication
I/O port	M12 (Socket-Female), 5-pin, A-coded, Push-Pull Number of ports: 8
Mounting method	Mounting hole: fixed with M4 screw
Grounding method	Grounding hole: fixed with M4 screw
Unit weight (packaged)	≈ 700 g (≈ 900 g)

Mode specifications

Mode	Digital Input
Number of channels	16-CH (I/Q: 8-CH, C/Q: 8-CH)
I/O common	NPN / PNP
Input current	5 mA
ON voltage/current	Voltage: ≥ 15 VDC≐ Current: ≥ 5 mA
OFF voltage	≤ 5 VDC≐

Mode	Digital Output
Number of channels	8-CH (C/Q)
I/O common	NPN / PNP
Power supply	24 VDC≐ (18 - 30 VDC≐), Max. 300 mA
Leakage current	≤ 0.1 mA
Residual voltage	≤ 1.5 VDC≐
Short circuit protection	YES

Mode	IO-Link
Input current	2 mA
ON voltage/current	Voltage: ≥ 15 VDC≐ Current: ≥ 2 mA
OFF voltage	≤ 5 VDC≐

Environmental conditions

Ambient temperature ⁰¹⁾	-5 to 70 °C, Storage: -25 to 70 °C (no freezing or condensation)
Ambient humidity	35 to 75%RH (no freezing or condensation)
Protection rating	IP67 (IEC standard), IP69K (DIN standard)

01) UL approved ambient temperature: 45 °C

Approvals

Approval	CE  
Association approval	

Communication Interface

Ethernet

Ethernet standard	100BASE-TX
Cable spec.	STP (Shielded Twisted Pair) Ethernet cable over Cat 5
Transmission rate	100 Mbps
Cable length	≤ 100 m
Protocol	EtherCAT

IO-Link

Version	1.1
Transmission rate	COM1 : 4.8 kbps / COM2 : 38.4 kbps / COM3 : 230.4 kbps
Port class	Class A
Standard	IO-Link Interface and System Specification Version 1.1.2 IO-Link Test Specification Version 1.1.2