



MS135B Series

Ø135mm Rotating
Warning Light

- Strong flash using reflector with 25W bulb
- Weather resistant lens and body
- LED bulb replacement available
- IP65 rated



Ordering Information

MS135B - B 01 - R
 ① ② ③

① Function	No mark	Reflector rotation
	B	Reflector rotation + Buzzer
② Power	01	12VDC
	02	24VDC
	10	110VAC
	20	220VAC
③ Lens Colors	R	Red
	Y	Yellow
	G	Green
	B	Blue
	C	Clear

Wiring Diagram

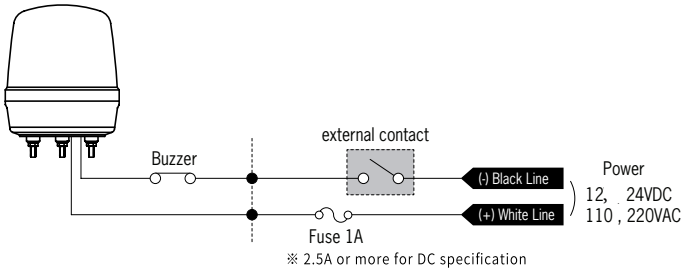

Dimensions

unit: mm

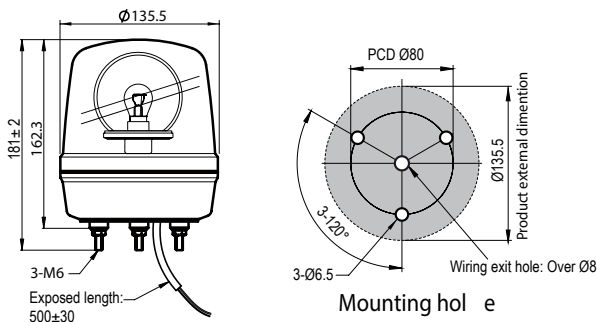

Replacement Parts

LED Bulb		MAL-T15-D-12-C	12V
		MAL-T15-D-24-C	24V
		MAL-T15-D-120-C	110V
		MAL-T15-D-240-C	220V
Incandescent BULB		MAM-T15-D-012-25	12V 25W
		MAB-T15-D-024-25	24V 25W
		MAB-T15-D-130-25	110V 25W
		MAB-T15-D-240-25	220V 25W

Specifications

Light source	Incandescent bulb			
Power Supply	12VDC	24VDC	110VAC	220VAC
Current Consumption	2.08A, 25W	1.04A, 25W	0.22A, 25W	0.11A, 25W
Rotation Rate	150 ±10% rpm/min			
Buzzer volume	90 ±5dB (1M) beep-beep-beep : The volume can not be adjusted			
Lens color	Red, Yellow, Green, Blue, Clear			
Mounting options	Stud/Pole/Wall mounting			
Connection method	Exposed wiring connections			
Ambient temperature	-15 ~ 50°C			
Storage ambient temperature	-20 ~ 70°C			
Ambient humidity	45 ~ 85% RH			
Dielectric strength	1 Min. at 1000VAC 50/60Hz			
Insulation Resistance	100MΩ or more (500VDC Megger basis)			
Vibration resistance	10 ~ 55Hz (1 min cycle) Double amplitude 0.75mm X, Y, Z			
Protection structure	IP65			
Connection	UL2464/22AWG			
Bulb life	1,000 hrs			
Approval	RoHS			
Weight	app.555g			