



ML115 Series

115mm Ultra-bright LED Warning Lights



- Car cigar jack type or lead wire type
- Strong magnet mounting or bolt mounting
- Excellent visibility with high-intensity LED and reflectors
- Emergency flashing and adjustable rotating light
- Can be used as vehicle emergency warning light

Ordering Information

ML115 J - M B 02 - R
 ① ② ③ ④ ⑤

① Power Supply	J	Cigar Jack Type for Vehicle
	C	Power Line Exposed Type
② Body Fixing Option	M	Magnet Mount
	G	Body Mount with Bolts
③ Buzzer Option	No mark	Standard
	B	Built-in Buzzer
④ Voltage	01	12VDC
	02	24VDC
⑤ Lens Color	R	Red
	Y	Yellow
	G	Green
	B	Blue
	C	Clear

Dimensions

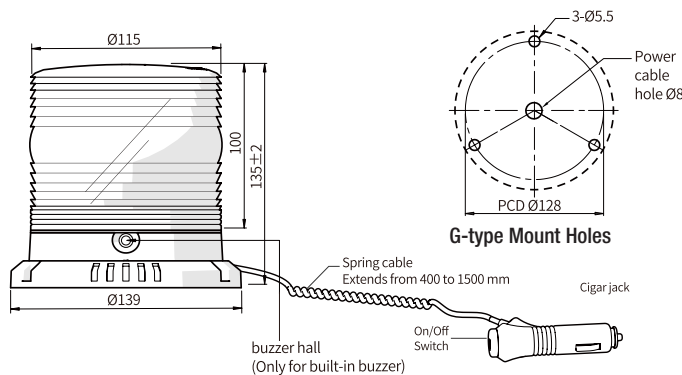

Specifications

LED Function	Flashing(emergency signal), Rotation
Power Supply	12VDC±5%, 24VDC±5%
Light Source	LED (Lifespan: 100,000h)
Dimension	Diameter 139mm (Base size)
Flashing Speed	220±5 times per minute
Rotation Speed	60~200rpm (Built-in control switch)
Buzzer Volume	90±5dB (at 1M)
Product Mounting	ML115□-M type: Detachable Magnetic Mount ML115□-G type: Body direct mount (M5 bolt)
Wiring Method	ML115J type: Cigar jack charging type ML115C type: Exposed wiring connection type
Ambient Temperature	-15°C~40°C
Storage Temperature	-20°C ~ 70°C
Ambient Humidity	45 ~ 85% RH
Voltage Withstand Capability	1 minute at 1000VAC 50/60Hz
Insulation Resistance	More than 100MΩ (500VDC Mega standard)
Vibration	10~55Hz(1minute cycle) 1 Hours double amplitude 0.75mm in X,Y,Z respective direction
Wiring Standard	ML115J type: UL2464/22AWG, Ø3.5, spring type cable 400~1500mm ML115C type: UL2464/22AWG, Ø4 exposure length 500±100mm
Degree of Protection	Standard IP65 / Buzzer type IP52 (Front direction)
Product Weight	ML115J-M : app. 683g. / ML115J-G : app. 380g ML115C-M : app. 680g / ML115C-G : app. 375g
Certification	CE, RoHS

LED Brightness

(±20 lm)

Red		Yellow		Green		Blue		White	
12V	24V	12V	24V	12V	24V	12V	24V	12V	24V
125	113	118	106	82	86	24	22	300	200

Current Consumption

LED Color	Red		Yellow		Green		Blue		White	
	12V	24V	12V	24V	12V	24V	12V	24V	12V	24V
Basic type	0.70A	0.30A	0.73A	0.33A	0.70A	0.25A	0.76A	0.25A	0.70A	0.20A
Buzzer type	0.72A	0.34A	0.75A	0.35A	0.72A	0.27A	0.78A	0.27A	0.72A	0.23A

Wall Mount Bracket

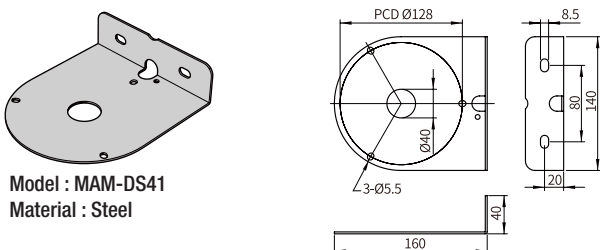

Model : MAM-DS41
Material : Steel

Connection Diagram

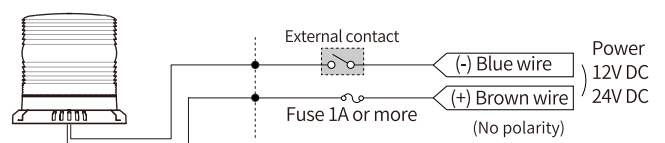

In case of ML115C type, LED light and buzzer operate at the same time when power is supplied.