

KL Series

Heavy Duty Limit Switches



- High reliability by silver plated contact of SPDT(1a+1b)
 - Low maintenance by die-cast aluminum body & stainless steel of moving parts
 - IP65 rated with built-in NBR gasket in body cover & O-ring in moving part
 - Single & multi conduits (PG13.5) for saving wiring time
 - 3 different sizes for diverse mounting application
- Reliable operation with physical lift-off system preventing any malfunction of contact (NC only)

Specifications

Contact Arrangement	Ag Alloy, SPDT(1NO+1NC)
Operation Speed	0.01mm/sec to 0.5m/sec
Insulation Resistance	100MΩ at 500V DC
Contact Resistance	Max. 50mΩ
Ambient Temperature	Operation: -25°C~ +80°C, Storage: -30°C~+80°C
Ambient Humidity	35~80%RH (at -5~+40°C)

Contact Rating

Rated Voltage	Non-Inductive Load				Inductive Load			
	Resistive Load		Lamp Load		Inductive Load		Motor Load	
	NO	NC	NO	NC	NO	NC	NO	NC
125VAC	10A	10A	1.5A	3A	6A	6A	2.5A	5A
250VAC	10A	10A	1A	2A	4A	4A	1.5A	3A
600VAC	1A	3A	0.5A	1A	1.5A	1.5A	0.5A	1A
8VDC	10A	10A	3A	6A	10A	10A	6A	6A
30VDC	6A	6A	3A	4A	6A	6A	4A	4A
125VDC	0.8A	0.8A	0.2A	0.2A	0.8A	0.8A	0.2A	0.2A

Operation Frequency	Electrical	Max. 30/min
	Mechanical	Max 120/min
Dielectric Strength	2,000VAC 1min	
Expected Life	Electrical	Min. 500,000
	Mechanical	Min. 10,000,000

Dimensions

unit: mm

KLSAP1

Push Plunger

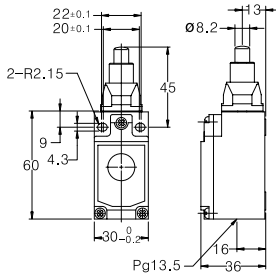

KLLAP1

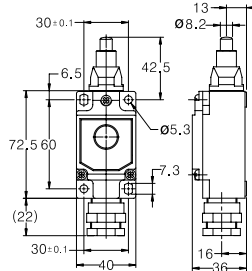

KLMAP1

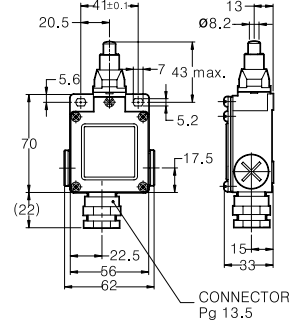

KLSAP2

Roller Plunger

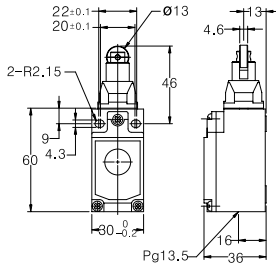

KLLAP2

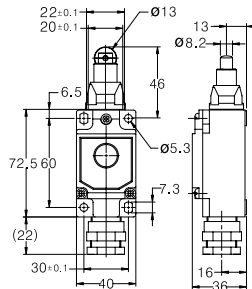

KLMAP2

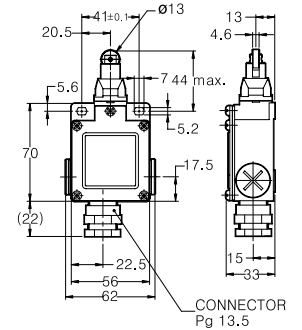

KLSAL1

Roller Lever Plunger

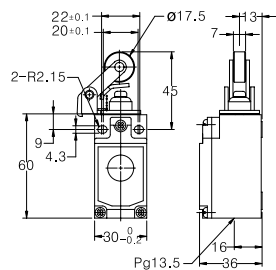

KLLAL1

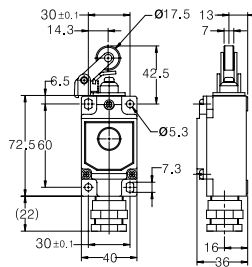

KLMAL1

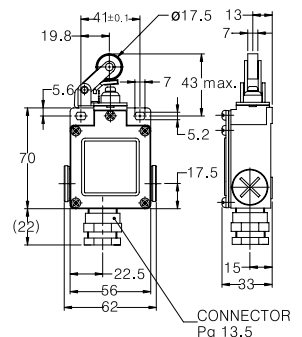

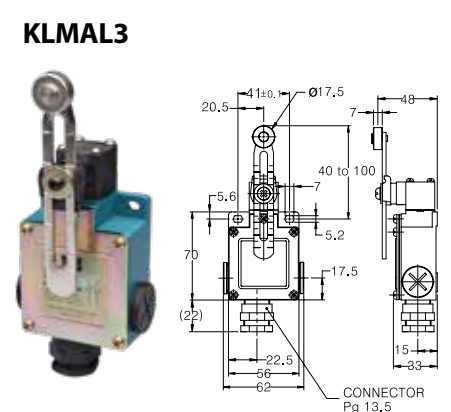
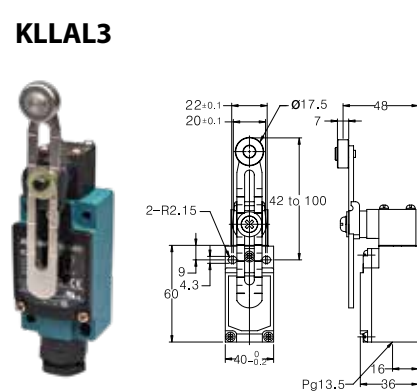
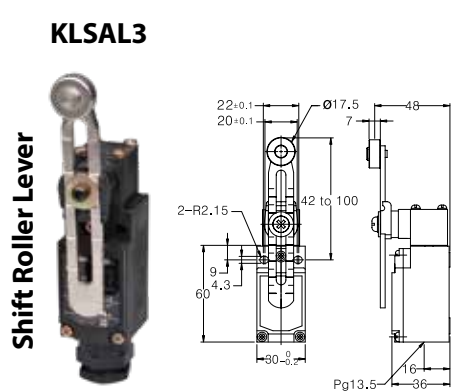
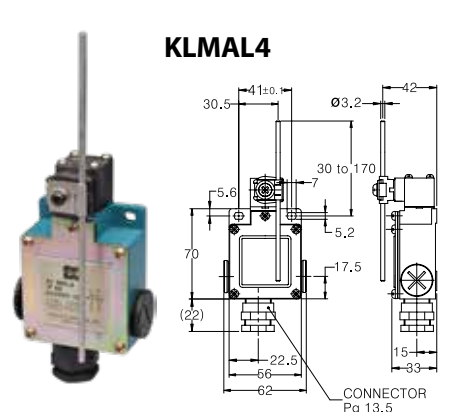
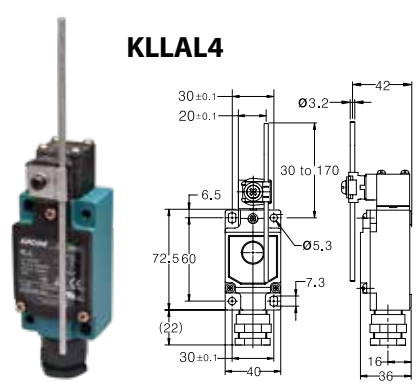
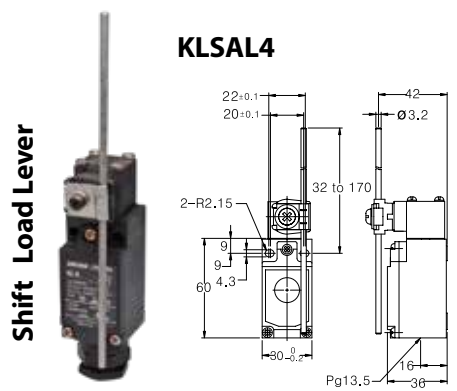
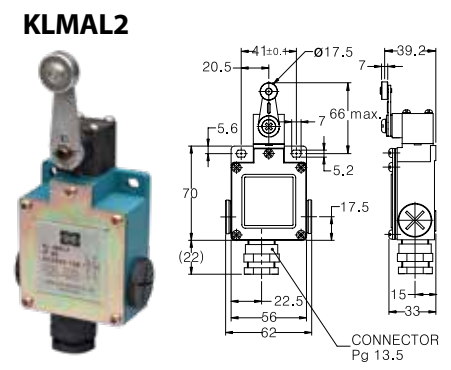
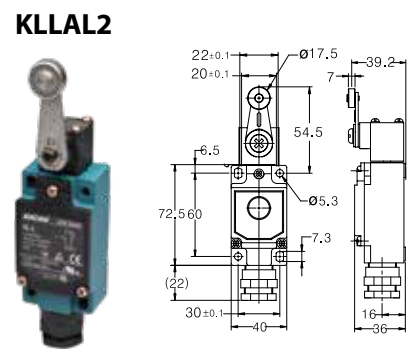
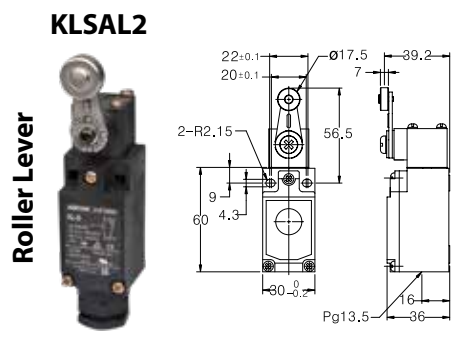

Operation Characteristics

	AP1	AP2	AL1	AL2	AL3	AL4
OF	2,720g	2,720g	700g	1,360g	1,360g	142g
RF	910g	910g	170g	227g	227g	28g
PT	1.7mm	1.7mm	4.5mm	20°±5	20°±5	20°±5
OT	6.4mm	5.6mm	6.4mm	40°	40°	40°
MD	1.0mm	1.0mm	1.0mm	12°	12°	12°
TF	-	-	-	2,720g	200g	200g

Contact Diagram

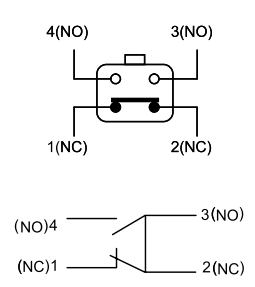

Roller Lever Operating Position Adjustment

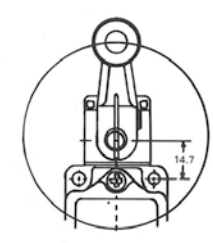

Assembly Guide

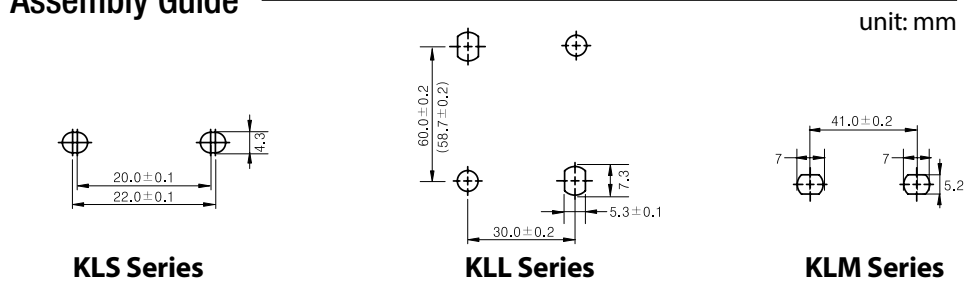

Loosen the bolt on the side of the roller lever to adjust angle.

Tower Lights

Beacon Lights

LED Indicators Pilot Lamps

Buzzer Alarms

Pushbutton Switches

Limit Switches

Foot Switches

SSR

Relay & Sockets

Relay Terminal Blocks

Terminal Blocks

Fuse Holders

Enclosures